

72x72 mm
Analogue, single channel

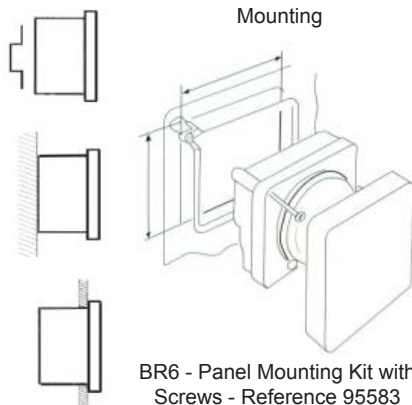

Dimensions & Electrical Connections

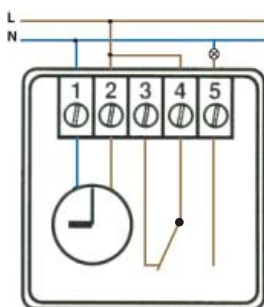
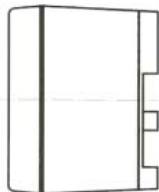
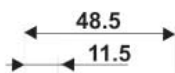
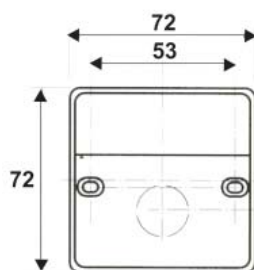

BR6 - Panel Mounting Kit with Screws - Reference 95583

Features

- Programming by captive segments. A red zone is uncovered when a tappet is moved to the ON status, and is hidden when the tappet is moved to the OFF position.
- Time of day shown by hands, allowing time setting by simple rotation in either direction. Summer/Winter time corrections are made easily.
- Manual override with automatic return to program. Contact status display
- Terminals in housing which opens for easy wiring.
- Surface, Panel or Din rail mounting
- Voltage free 16A changeover contact

Panel Mounting Options

- Fit using supplied back box - maximum panel thickness - 2mm (Connections made into back box)
- Fit using BR6 panel mounting kit - maximum panel thickness - 4mm (Connections made via tab terminals - back box discarded)

Functional characteristics

Daily Version

- Programming in steps of 10 minutes
- Minimum interval between 2 switchings: 20 minutes (two tappets)
- 72 switchings per day
- Switching accuracy: 1 minute 30 seconds

Weekly Version

- Programming in steps of one hour
- Minimum interval between 2 switchings: 2 hours (two tappets)
- 84 switchings per week
- Switching accuracy: 10 minutes

Technical characteristics

Supply voltage		230V + 10% -15%
Frequency		50/60 Hz
Power consumption		approx. 0.5 VA
Changeover contacts	resistive load	16 A 250 V
	voltage free	3 A 250 V
	inductive load (cos φ = 0.6)	1000 W 250 V
	incandescent lamps	350 W 250 V
	squirrel-cage motor	
Time base		Quartz
Accuracy of operation		1 sec / 24 h.
Operating temperature		-10 °C to +50 °C
Storage temperature		-20 °C to +60 °C
Connection by cage terminals, section of conductors		1 to 6 mm
Insulation class		II
Protection index		IP 20
Conformity to standard BS EN 60730		yes
Performance indicated for an ambient temperature of 20 °C		

Reference	Cycle	Power reserve	Voltage free changeover contacts
16621	24 hour	200 hour	16 (3) A
16622	24 hour	-	16 (3) A
16921	7 day	200 hour	16 (3) A
16922	7 day	-	16 (3) A

Reference Accessories

95583	BR6 Panel Mounting Kit with Screws
-------	------------------------------------

Sangamo Limited
Industrial Estate, Port Glasgow, Renfrewshire, PA14 5XG
Tel: 0845 006 6206 Fax: 01475 744567
Email : enquiries@sangamo.co.uk Web: www.sangamo.co.uk

DS/DP/0006/B