

72x72 mm

Electronic, single channel

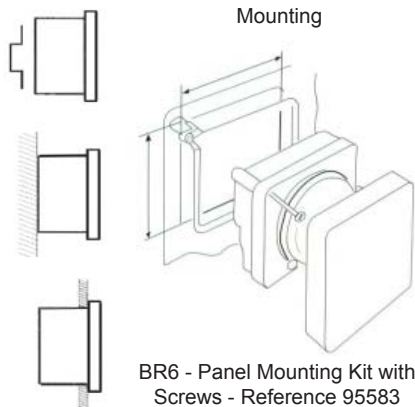

Dimensions & Electrical Connections

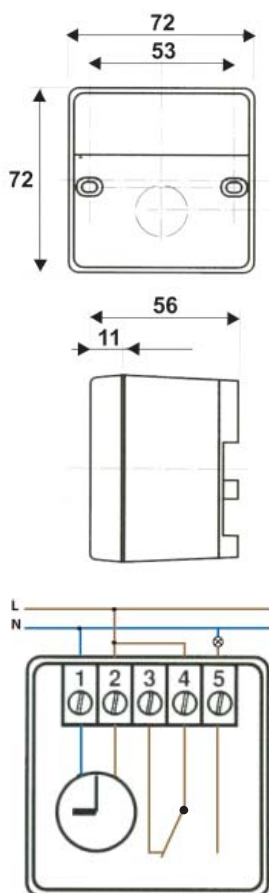

	Features
--	----------

• Pull-out timer with tab terminals integrated within housing. Suitable for Surface, Din Rail and Panel Mounting.

Panel Mounting Options

- Fit using supplied back box - maximum panel thickness - 2mm (Connections made into back box)
- Fit using BR6 panel mounting kit - maximum panel thickness - 4mm (Connections made via tab terminals - back box discarded)

	Functional characteristics
--	----------------------------

Daily Version

• 20 set points (ON or OFF) in total

Weekly Version

• 20 set points (ON or OFF) in total, each set point can be assigned to one, several or all days of the week (providing up to a total of 140 switchings per week)

• Programming in 1 minute steps

• Manual position allows the following:

- permanent ON or OFF by leaving the slider in position
- or a timed override by returning to AUTO mode after the override time period (1 to 23 hours or 1 to 27 days programmable)

• Lithium battery: total of 25,000 hours minimum reserve

	Technical characteristics
--	---------------------------

Supply voltage	230V + 10% -15%
Frequency	50/60 Hz
Power consumption	approx. 1 VA
Changeover contacts	resistive load 8 A 250 V
voltage free	inductive load (cos φ = 0.6) 2 A 250 V
Accuracy of operation	1 sec / 24 h.
Operating temperature	-10 °C to +50 °C
Storage temperature	-20 °C to +60 °C
Connection by cage terminals, section of conductors	1 to 6 mm ²
Insulation class	II
Protection index	IP 20
Conformity to standard BS EN 60730	yes

Performance indicated for an ambient temperature of 20 °C

Reference	Cycle	Power reserve	Voltage free changeover contacts
-----------	-------	---------------	----------------------------------

23171	24 hour	Lithium battery	8 (2) A
23671	7 day	Lithium battery	8 (2) A

Reference	Accessories
-----------	-------------

95583	BR6 Panel Mounting Kit with Screws
-------	------------------------------------

Sangamo Limited
Industrial Estate, Port Glasgow, Renfrewshire, PA14 5XG
Tel: 0845 006 6206 Fax: 01475 744567
Email : enquiries@sangamo.co.uk Web: www.sangamo.co.uk

DS/DP/0007/B